

# SAFE TRANSPORT WITH NEW WHEELS



www.pramet.com

INDEXABLE CUTTING INSERTS  
RCMH - RCMT - RCMX - RCUM

## MACHINING OF NEW RAILWAY WHEELS

 **PRAMET**

# RAILWAY WHEELS

Railway wheels are very important parts of the train. These parts ensure the only contact with the rails. Therefore a high demand on wheel surface quality is needed. Roughness and shape precision has a major significance for forces, wear behavior, friction and vibrations.

In the contact zone between railway wheel and rail the surfaces and bulk material must be strong enough to resist the normal (vertical) **forces** introduced by heavy loads and the dynamic response induced by track and wheel irregularities. The tangential forces in the contact zone must be low enough to allow moving heavy loads with little resistance, at the same time the tangential loads must be high enough to provide traction, braking, and steering of the trains.

**Wear** occurs in the contact under the poorly lubricated condition due to sliding that is typical of wheel – rail contact.

**The friction** between the wheels and rail is extremely important as it plays a major role in the wheel – rail interface process such as adhesion, wear, rolling contact fatigue, and noise generation. Effective control of friction through the application of friction modifiers to the wheel – rail contact is therefore clearly advantageous, although the process has to be carefully managed. The aim of friction management is to maintain friction levels in the wheel – rail contact to give.

Railway operations also generate vibrations that are transmitted through the ground into neighboring properties. These can lead either to feel able **vibration** (in the range 4 to 80 Hz) or to low frequency rumbling **noise** (30 to 250 Hz). Vibrations are also transmitted into the vehicle itself, affecting passenger comfort. The most important mechanical noise source from a train is generated at the wheel – rail contact. Rolling noise is caused by vibrations of the wheel and track structures, induced at the wheel – rail contact point by vertical irregularities in the wheel and rail surfaces.

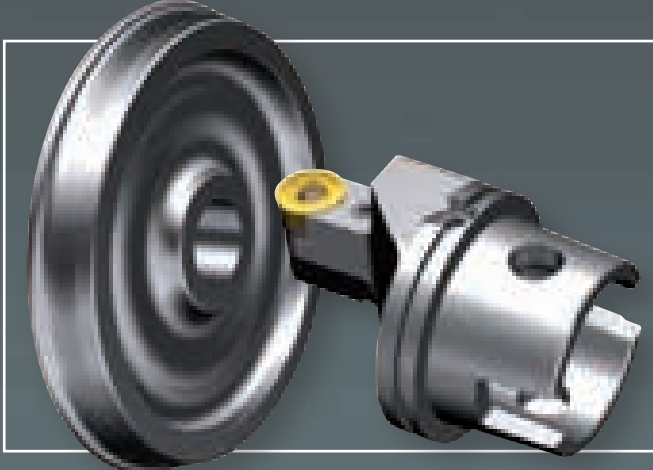

Company Pramet has longtime experience with machining of railway wheels. We are aiming to meet the most demanding requirements in terms of quality, reliability and productivity.

Nowadays, we cooperate with dozen of factories around the world with a total annual production more than 8 000 000 wheels. We also deliver high quality and level of technical service.

We are your partner in railway industry. Here is something from our menu - returning of railway wheels, machining of wheel-set axles, chassis, milling of rails, switches, base plates and wagon parts.

## We can offer:

- Reliable cutting process
- Lifetime and productivity
- Optimal chip breaking
- Dimension accuracy and stability
- Surface quality
- Continuous development

## Influences to cutting process:

- Cutting conditions
- Geometry and micro-geometry
- Cutting material
- Workpiece hardness (250-340HB)
- Cooling
- Machine power and rigidity

# MACHINING PROCESS

Machining of railway wheels is very specific technology, which is based on principle of copying the shape by round cutting edge. One of the main issues is to determine the optimal chip thickness with respect to force balance, heat distribution as well as to ideal chip breaking. Pramet gives you optimal and economic solution for your production.

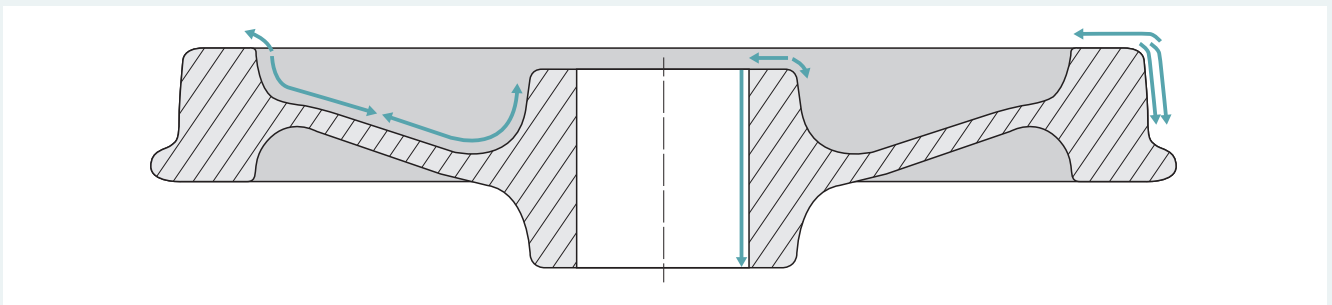
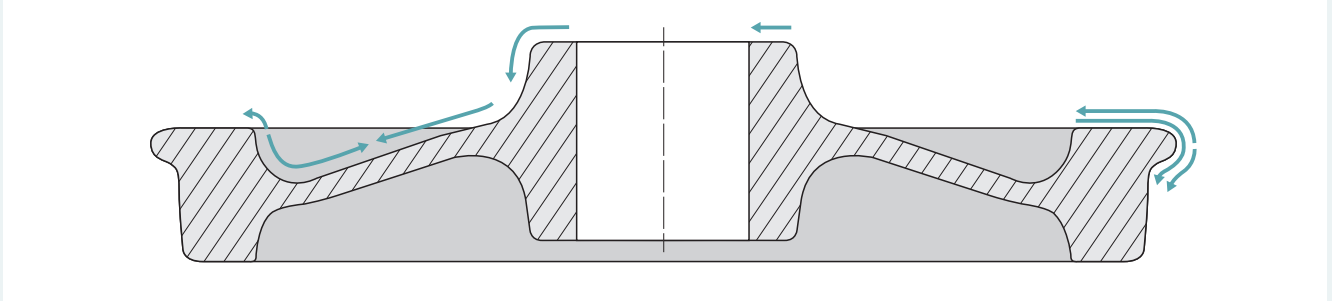

## NOMENCLATURE

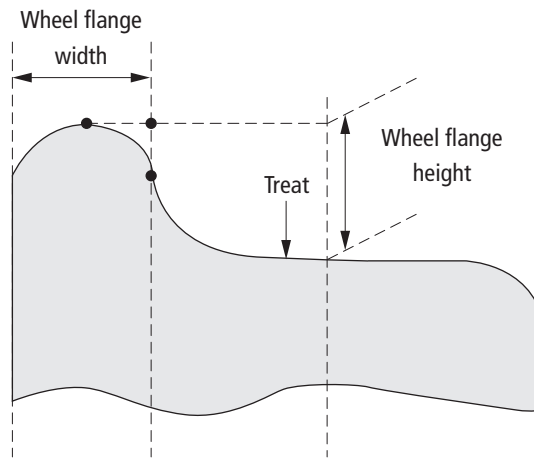

## MIDDLE CHIP THICKNESS

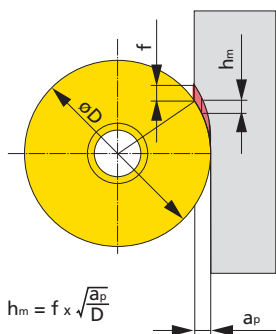

### Recommended middle chip thickness

Insert	Chipbreaker	hm
RCMX 2006 MO	RF1	0,225
RCMX 2006 MO	RM1	0,25
RCMX 2507 MO	RF1	0,275
RCMX 2507 MO	RM1	0,35
RCMX 2507 MO	RM2	0,425
RCUM 3010 MO	RR7	0,45
RCMT 3009 MO	RR4	0,45
RCMX, RCMH 3209 MO	RM2	0,45
RCMX, RCMH 3209 MO	RR2	0,45

# ASSORTMENT

## RCMX / RCUM / RCMT

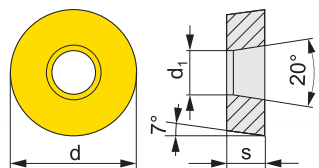

Size	d	d <sub>1</sub>	s
2006	20	6,5	6,35
2507	25	7,2	7,94
3009	30	10	9,52
3010	30	10	9,6
3209	32	10,5	9,52

ISO	Grades				Feed per rev.		Depth of cut	
	T9310	T9315	T9325	T9335	f <sub>min</sub>	f <sub>max</sub>	a <sub>pmin</sub>	a <sub>pmax</sub>
RCMX 2006MO-RF1	●	●	●	●	0,45	1,20	1,00	5,00
RCMX 2006MO-RM1	●	●	●	●	0,50	1,30	1,50	5,00
RCMX 2507MO-RF1	●	●	●	●	0,60	1,20	1,50	7,00
RCMX 2507MO-RM1	●	●	●	●	0,70	1,20	2,00	7,00
RCMX 2507MO-RM2	●	●	●		0,70	1,20	2,00	7,00
RCUM 3010MO-RR7	○	○			0,90	1,60	2,00	8,00
RCMT 3009MO-RR4	○	○			0,80	1,50	4,00	8,00
RCMX 3209MO-RM2	●	●	●	●	0,80	1,30	2,00	8,00
RCMX 3209MO-RR2	●	●	●		0,80	1,50	2,50	8,00

## RCMH

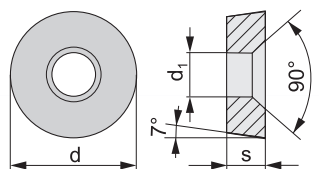

Size	d	d <sub>1</sub>	s
3209	32	10,5	9,52

ISO	Grades			Feed per rev.		Depth of cut	
	T9310	T9315	T9325	f <sub>min</sub>	f <sub>max</sub>	a <sub>pmin</sub>	a <sub>pmax</sub>
RCMH 3209MO-RM2	●	●	●	0,80	1,30	2,00	8,00
RCMH 3209MO-RR2	●	●	●	0,80	1,50	2,50	8,00

All dimensions in [mm]

● Stock assortment ○ Non-stock assortment

# TECHNICAL INFORMATION

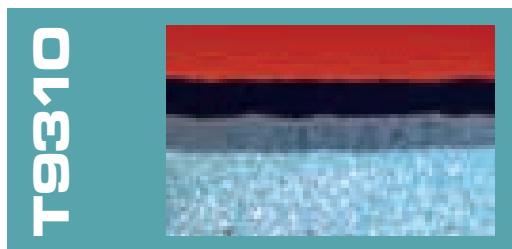

T9310

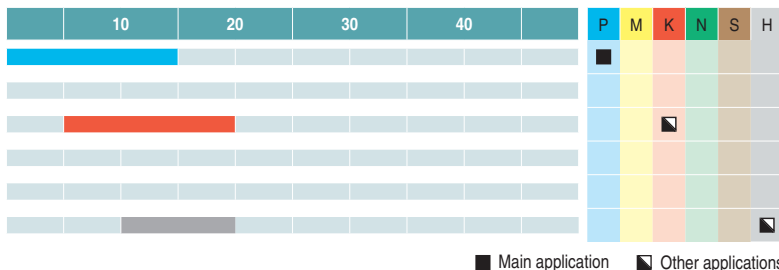

- Fine grained functional gradient substrate
- Low content of cobalt
- Thick MT-CVD coating with a superior  $Al_2O_3$  outer layer
- Exceptional thermal and chemical stability providing excellent protection of the substrate

- Special adjustment of surface after coating
- Primarily aimed for machining of materials group P and K conditionally H
- High cutting speeds
- Continuous and moderately interrupted cuts

First choice

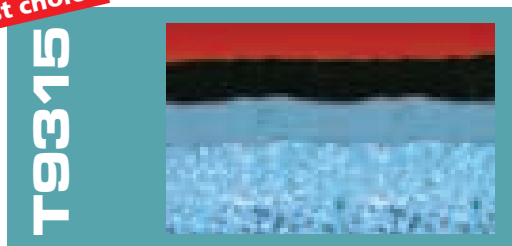

T9315

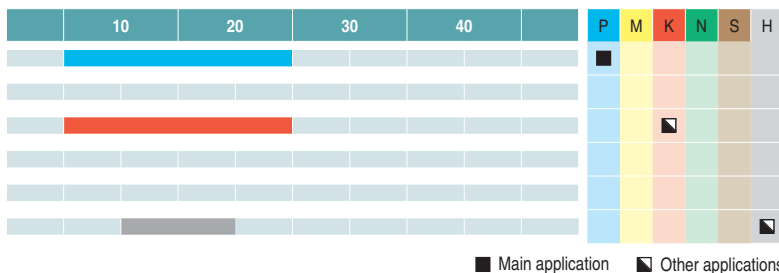

- New generation of grades T9300 is characterized by high wear resistance with considerable toughness
- Functional gradient substrate with relatively low content of cobalt binder phase
- Thick MT-CVD coating with unique  $Al_2O_3$  top layer warrants extra-ordinary thermal, chemical stability and protection of substrate

- Special final treatment after coating
- Machining of material group P, conditionally K, H
- Finishing, continuous and reasonably interrupted cuts
- High stability of cutting edge
- High cutting speed

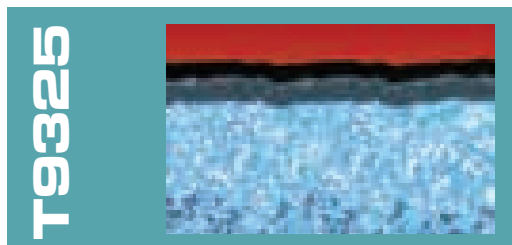

T9325

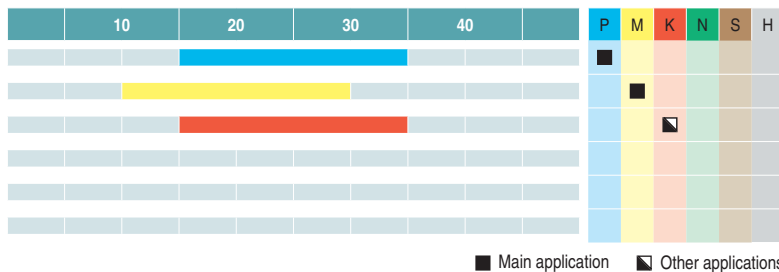

- The most versatile grade of new generation T9300
- Functional gradient substrate with moderate content of cobalt binder phase
- Medium thick MT-CVD coating with unique  $Al_2O_3$  top layer warrants extra-ordinary thermal and chemical stability and protection of substrate

- Special final treatment after coating
- Machining of material group P, M conditionally K
- Versatile application
- Unfavourable cutting conditions, continuous and/or interrupted cuts
- Medium and higher cutting speed





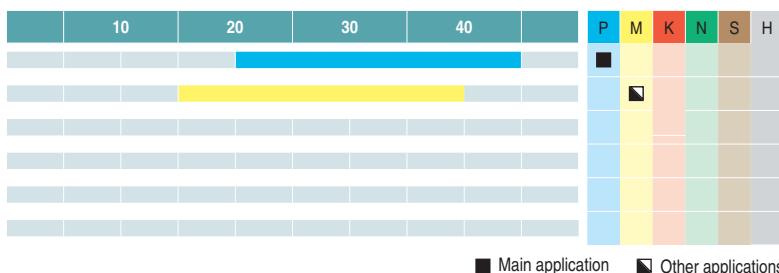

T9335





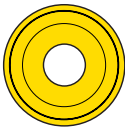

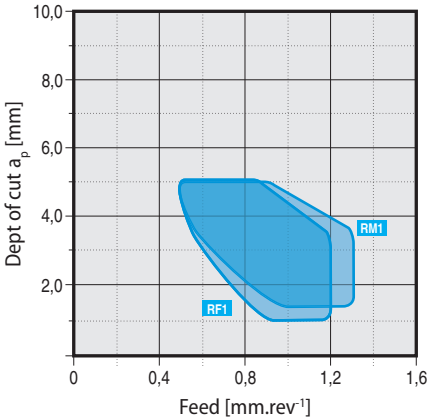

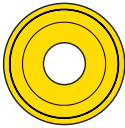

- Functional gradient substrate with medium grain size
- Relatively high cobalt content
- Medium thick MT-CVD coating
- Grade characterized by very high toughness
- Special surface treatment after coating

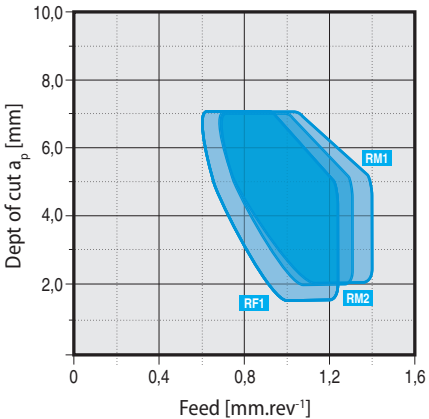
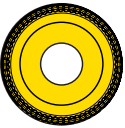
- Machining of material group P, conditionally M and S
- Medium cutting speeds
- Continuous and heavy interrupted cuts
- Good performance under very unfavorable cutting conditions





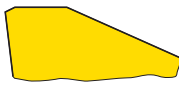
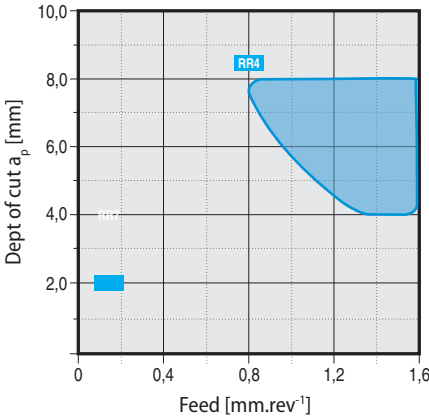



# OVERVIEW OF GEOMETRIES

Size 20	Designation	Finishing	Medium	Roughing	Chipbreaker	Diagram of application
	RCMX 2006MO-RF1	■				
<b>First choice</b> 	RCMX 2006MO-RM1		■			

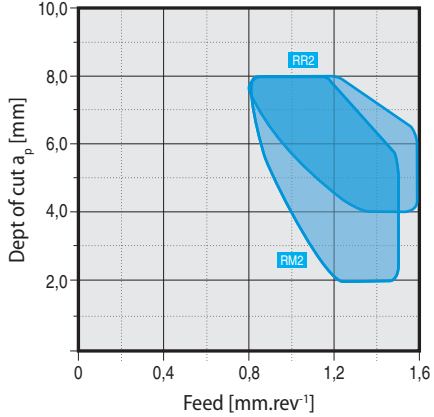
Size 25	Designation	Finishing	Medium	Roughing	Chipbreaker	Diagram of application
	RCMX 2507MO-RF1	■				
	RCMX 2507MO-RM1		■			
<b>First choice</b> 	RCMX 2507MO-RM2		■			

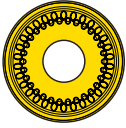
Size 30	Designation	Finishing	Medium	Roughing	Chipbreaker	Diagram of application
	RUCM 3010MO-RR7			■		
	RCMT 3009MO-RR4			■		

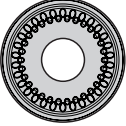
# OVERVIEW OF GEOMETRIES

Size 32	Designation	Finishing	Medium	Roughing	Chipbreaker	Diagram of application
<b>First choice</b> 	RCMX 3209MO-RM2		■			
<b>First choice</b> 	RCMH 3209MO-RM2		■			
	RCMX 3209MO-RR2			■		
	RCMH 3209MO-RR2			■		





CZECH REPUBLIC • PRAMET Tools, s.r.o., Unicořská 2, CZ -787 53 Sumperk,  
Phone: +420 583 381 111, Fax: +420 583 215 401, E-mail: pramet.info.row@pramet.com



[youtube.com/pramettv](https://www.youtube.com/pramettv)

---

[www.pramet.com](http://www.pramet.com)

Railway Helpdesk: [railway@pramet.com](mailto:railway@pramet.com)



880895